

SD Series™ Cord and Light Reel

3A2826E
EN

For storing electric cord used to provide electricity and/or light. For indoor and dry location use only.

Not approved for use in explosive atmospheres or hazardous locations.

Models: pages 3 and 4



Important Safety Instructions
Read all warnings and instructions in this
manual and in SD Series Cord and Light Reel
Installation manual. Save all instructions.

Size 10 Model

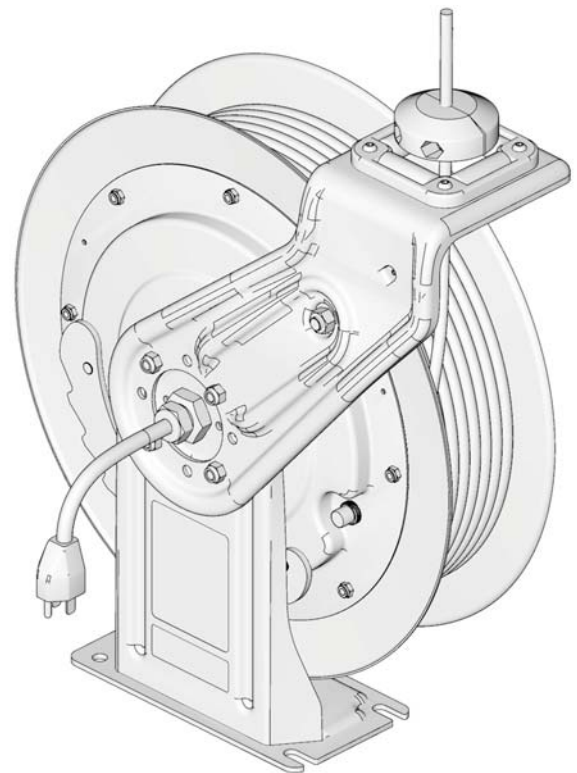

Size 5 Model

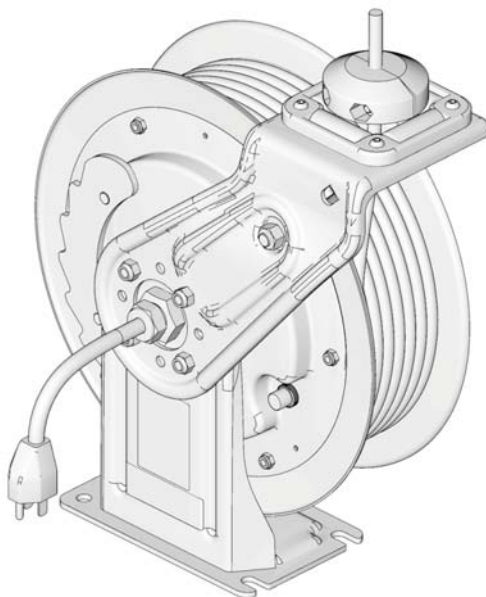

Table of Contents

120 Volt Models	3
230 Volt Models	4
Warnings	5
Component Identification	7
Adjusting Spring Tension	8
Troubleshooting	9
Repair	11
Replacing the Spring Cassette	11
Replacing the Accessory Cord	12
Electrical Power Cords	17
Slip Ring Replacement	19
Single Industrial Receptacle	21
Fluorescent Light (16N223)	22
Fluorescent Light with Tool Tap (16N224)	22
LED Light 120V (127088)	23
Tool Tap 120V (16N226)	23
LED Light 230V (16N225)	23
Tri-Plug GFCI Industrial Receptacle(24N880) ..	24
Replacement Bulbs	25
For Fluorescent Lights - 16P697	25
For 230V LED Lights - 16P1696	25
Parts	
Size 5 shown	26
Size 5 and Size 10 Models	27
Kits	29
Technical Data	33
Dimensions - Size 5 and Size 10 Models	34
Notes	35
Graco SD Series™ Cord and Light Reel Warranty	36

Related Manuals

- 3A2592 - SD Electric Cord Reel Instructions
- 3A2828 - Reel Enclosure Installation
- 406742 - Ball Stop Kit
- 406743 - Roller Guide Kit

120 Volt Models



Model		Description			Size		Cord Length	Insulation	Power Cord Connect	Accessory
Blue	Black		Wire Gauge (AWG)	Current (Amperes)	Size 5	Size 10				
24M510	24Y858	Cord, No Accessory	16	13	✓		50 feet 15 meters	SJTOW	NEMA 5-15P	-
24M511	24Y879		16	10		✓	95 feet 29 meters	SJTOW	NEMA 5-15P	-
24M512	24Y859		12	20	✓		50 feet 15 meters	SJOOW	NEMA 5-20P	-
24M513	24Y880		12	18		✓	95 feet 29 meters	SJOOW	NEMA 5-20P	-
24M517	24Y860	Single Industrial Receptacle	16	13	✓		35 feet 10 meters	SJTOW	NEMA 5-15P	NEMA 5-15R
24M518	24Y861		16	13	✓		50 feet 15 meters	SJTOW	NEMA 5-15P	NEMA 5-15R
24M521	24Y862		12	20	✓		35 feet 10 meters	SJOOW	NEMA 5-20P	NEMA 5-20R
24M522	24Y863		12	20	✓		50 feet 15 meters	SJOOW	NEMA 5-20P	NEMA 5-20R
24M523	24Y881		12	18		✓	75 feet 225 meters	SJOOW	NEMA 5-20P	NEMA 5-20R
24M524	24Y882		12	18		✓	95 feet 29 meters	SJOOW	NEMA 5-20P	NEMA 5-20R
24M525	24Y864	Tri-Plug GFCI Industrial Receptacle	12	15	✓		50 feet 15 meters	SJOOW	NEMA 5-15P	Tri-Plug NEMA 5-15R
24M526	24Y883		12	15		✓	95 feet 29 meters	SJOOW	NEMA 5-15P	Tri-Plug NEMA 5-15R
24M527	24Y865	Fluorescent Light	16	0.3	✓		35 feet 10 meters	SJTOW	NEMA 5-15P	16N223
24M528	24Y866		16	0.3	✓		50 feet 15 meters	SJTOW	NEMA 5-15P	16N223
24M529	24Y884		16	0.3		✓	95 feet 29 meters	SJTOW	NEMA 5-15P	16N223
24M530	24Y867	Fluorescent Light with Tool Tap	16	10	✓		35 feet 10 meters	SJTOW	NEMA 5-15P	16N224
24M531	24Y868		16	10	✓		50 feet 15 meters	SJTOW	NEMA 5-15P	16N224
24M532	24Y885		16	10		✓	95 feet 29 meters	SJTOW	NEMA 5-15P	16N224
24M533	24Y869	LED Light	16	0.05	✓		35 feet 10 meters	SJTOW	NEMA 5-15P	127088
24M534	24Y870		16	0.05	✓		50 feet 15 meters	SJTOW	NEMA 5-15P	127088
24M535	24Y886		16	0.05		✓	95 feet 29 meters	SJTOW	NEMA 5-15P	127088
24M536	24Y871	LED Light with Tool Tap	16	12	✓		35 feet 10 meters	SJTOW	NEMA 5-15P	127088 - light 16N226 - tool tap
24M537	24Y872		16	12	✓		50 feet 15 meters	SJTOW	NEMA 5-15P	127088 - light 16N226 - tool tap
24M538	24Y887		16	10		✓	95 feet 29 meters	SJTOW	NEMA 5-15P	127088 - light 16N226 - tool tap

230 Volt Models

Model		Description			Size		Cord Length	Insulation	Power Cord Connect	Accessory
Blue	Black		Wire Gauge	Current (Amperes)	Size 5	Size 10				
24M514	24Y873	Cord, No Accessory	1,5 mm ²	10	✓		10 meters	H05RR-F	-	-
24M515	24Y874		1,5 mm ²	10	✓		15 meters	H05RR-F	-	-
24M516	24Y888		2,5 mm ²	16		✓	25 meters	H07RN-F	-	-
24M539	24Y877	LED Light	1,5 mm ²	0.05	✓		10 meters	H05RR-F	CEE 7/7 16 A	16N225
24M540	24Y878		1,5 mm ²	0.05	✓		15 meters	H05RR-F	CEE 7/7 16 A	16N225
24M541	24Y890		1,5 mm ²	0.05		✓	25 meters	H05RR-F	CEE 7/7 16 A	16N225
24M542	24Y875	Single Industrial Receptacle	1,5 mm ²	10	✓		10 meters	H05RR-F	CEE 7/7 16 A	CEE 7/7 16 A
24M543	24Y876		1,5 mm ²	10	✓		15 meters	H05RR-F	CEE 7/7 16 A	CEE 7/7 16 A
24M544	24Y889		2,5 mm ²	16		✓	25 meters	H07RN-F	CEE 7/7 16 A	CEE 7/7 16 A

Warnings

The following warnings are for the setup, use, grounding, maintenance, and repair of this equipment. The exclamation point symbol alerts you to a general warning and the hazard symbols refer to procedure-specific risks. When these symbols appear in the body of this manual or on warning labels, refer back to these Warnings. Product-specific hazard symbols and warnings not covered in this section may appear throughout the body of this manual where applicable.

DANGER



ELECTRIC SHOCK HAZARD

This equipment must be grounded. Improper grounding setup, or misuse of the cord reel can cause fire or death by electric shock. In the event of an electrical short circuit, grounding reduces the risk of electric shock by providing an escape wire for the electric current. This product is equipped with a cord having a grounding wire with an appropriate grounding plug. The plug must be plugged into an outlet that is properly installed and grounded in accordance with all local codes and ordinances.



- This product is for use on a nominal 120V or 230V circuit and has a grounding plug similar to the plugs illustrated in the figure below.
- Connect only to grounded electric outlet. Fully insert plug into outlet. Do not connect a three-prong plug to a two-hole outlet.
- Fully insert appliance plug into end of accessory cord. Do not connect a three-prong appliance plug to a two hole cord reel.
- Do not remove, bend or modify any metal prongs or pins of cord reel or appliances plugged into cord reel.

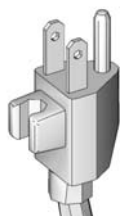

120V US



230V



- Do not modify the plug provided; if it does not fit the outlet, have the proper outlet installed by a qualified electrician.
- Make sure appliances are off before connecting cord reel to outlet.
- Do not use excessive force to make connections.
- Cord reel is marked for indoor use and is to be used indoors only. Always store cord reel indoors.
- Keep cord reel and accessories away from water. Do not use when wet.
- Grasp plug to remove from outlet. Do not unplug by pulling on power cord.
- Look for the number of watts or amperes on appliances to be plugged into cord reel. See label on cord reel for specific wattage or amperage. Do not plug more than the specified number of watts or amperage into this cord reel.
- All electrical wiring must be done by a qualified electrician and comply with all local codes and regulations.

	<p>FIRE AND EXPLOSION HAZARD</p> <p>When flammable fluids are present in the work area, such as gasoline and windshield wiper fluid, be aware that flammable fumes can ignite or explode. To help prevent fire and explosion:</p> <ul style="list-style-type: none"> • When installing a cord reel above a hazardous location the reel must be mounted at such a height that the lamp guard cannot reach within 18 inches of the floor. • Do not plug one cord reel into another. • Avoid overheating, do not cover cord reel or accessories with any material. • Always unplug cord reel when not in use. • Use equipment only in well ventilated area. • Eliminate all ignition sources, such as cigarettes and portable electric lamps. • Keep work area free of debris, including rags and spilled or open containers of solvent and gasoline. • Do not plug or unplug power cords or turn lights on or off when flammable fumes are present. • Stop operation immediately if static sparking occurs or you feel a shock. Do not use equipment until you identify and correct the problem. • Keep a working fire extinguisher in the work area.
	<p>EQUIPMENT MISUSE HAZARD</p> <p>Misuse can cause death or serious injury.</p> <ul style="list-style-type: none"> • Inspect thoroughly before each use. Do not use if damaged. Replace worn or damaged parts immediately with genuine manufacturer's replacement parts only. • Do not alter or modify equipment. Alterations or modifications may void agency approvals and create safety hazards. • Make sure cord reel is rated and approved for the environment in which you are using it. • Use equipment only for its intended purpose. Call your distributor for information. • Route power cords and accessory cords away from traffic areas, sharp edges, moving parts, and hot surfaces. Do not run cord through ceilings, walls or floors. • Do not drive, drag or place objects over cord reel cord. • Do not walk on cord. • Do not use cord to pull equipment. • Keep children and animals away from work area. • Comply with all applicable safety regulations.

 **WARNING**

	<p>MOVING PARTS HAZARD</p> <p>Moving parts can pinch, cut or amputate fingers and other body parts.</p> <ul style="list-style-type: none"> • Keep clear of moving parts. • Do not operate equipment with protective guards or covers removed.
---	--

Component Identification

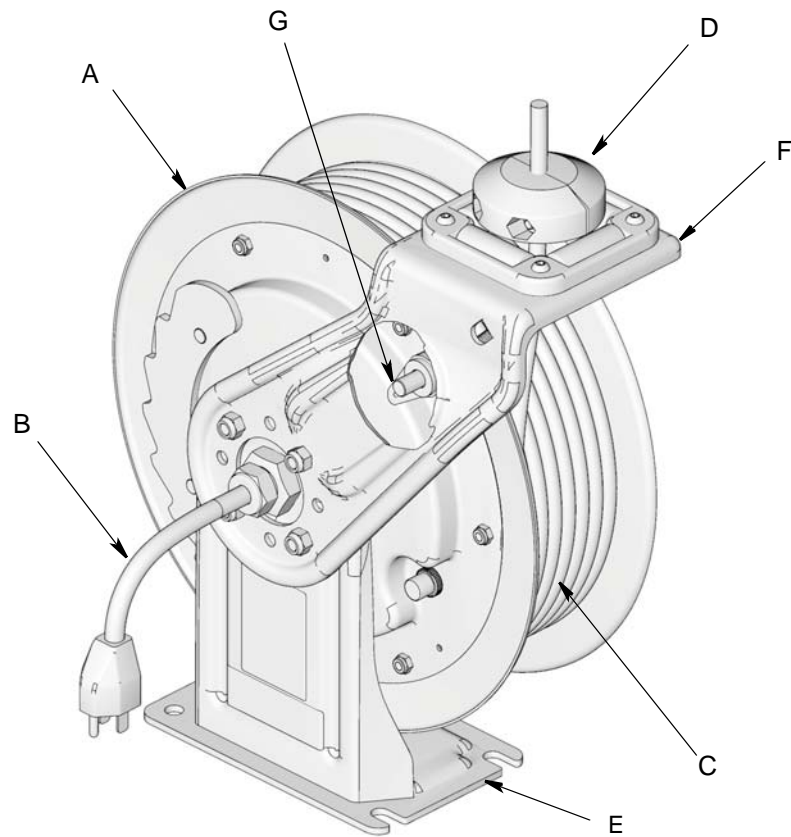





FIG. 1

Key:

- A Spool
- B Power Cord
- C Accessory Cord
- D Cord Stop
- E Base Plate
- F Support Arm
- G Pawl (cutaway view - part is located behind support arm)

Adjusting Spring Tension

						
<ul style="list-style-type: none"> • Never allow reel to spin freely. Doing so could cause serious injury if you are hit by the plug, accessories, or other moving parts. • Reel must be bolted securely in place when making adjustments. 						

						
---	---	---	--	--	--	--

Increasing Spring Tension

1. Disconnect cord reel from power source by unplugging power cord from outlet.
2. Pull out accessory cord, 1 to 2 turns and engage pawl.
3. Pull accessory cord back through cord rollers.
4. Wrap a loop of accessory cord onto the spool. See Table 1, Recommended Number of Pre-Turns.
5. Check the spring tension; the accessory cord must pull out fully and retract fully. Wrap more loops, one at a time around the spool until the spring has the desired tension.

NOTE: Do not put so many loops onto the reel that the spring winds up tightly before the accessory cord is fully extended.

Decreasing Spring Tension

1. Disconnect cord reel from power source by unplugging power cord from outlet.
2. Pull out accessory cord, 1 to 2 turns and engage pawl.
3. Pull accessory cord back through cord rollers.
4. Remove loops of accessory cord to decrease tension.
5. Check the spring tension. Unwrap more loops, one at a time from the spool until the spring has the desired tension.

**Table 1:
Recommended Number of Pre-Turns**

Model		No. of Turns
Blue	Black	
24M510	24M858	2
24M511	24M879	2
24M512	24M859	3
24M513	24M880	3
24M514	24M873	3
24M515	24M874	2
24M516	24M888	3
24M517	24M860	3
24M518	24M861	2
24M521	24M862	3
24M522	24M863	3
24M523	24M881	3
24M524	24M882	3
24M525	24M864	3
24M526	24M883	3
24M527	24M865	3
24M528	24M866	2
24M529	24M884	2
24M530	24M867	3
24M531	24M868	2
24M532	24M885	2
24M533	24M869	3
24M534	24M870	2
24M535	24M886	2
24M536	24M871	3
24M537	24M872	2
24M538	24M887	2
24M539	24M877	3
24M540	24M878	2
24M541	24M890	3
24M542	24M875	3
24M543	24M876	2
24M544	24M889	3

Troubleshooting



Problem	Cause	Solution
Cord will not retract fully	Outlet attachment is too heavy	Increase spring tension. See Increasing Spring Tension, page 8.
	Spring lost tension	
	Spring is broken	Replace spring. See Replacing Spring Cassette instructions, page 11.
Cord will not retract at all	Spring is broken	Replace spring. See Replacing Spring Cassette, page 11.
	Spring has lost tension	Increase spring tension. See Increasing Spring Tension, page 8.
Reel will not latch	Broken pawl	Replace pawl. See instruction manual included with Latch Kit 15Y503.
	Broken pawl spring	Replace pawl spring. See instruction manual included with Latch Kit 15Y503.
	Pawl not lined up with ratchet plate.	See FIG. 13, page 16 for correct operating position. Realign pawl with ratchet plate if not correctly positioned. See Step 17, page 16.
No electrical power at the output end of accessory cord	Accessory disconnected from cord end	Reconnect accessory to output end of accessory cord.
	Accessory is broken	Replace accessory.
	Wires are not connected	Check all connections. Reconnect any loose wires connections. Or replace cord if problem with cord is discovered
	Worn slip-ring /brushes	Replace worn slip-ring/brushes, page 19.
Cord reel is not providing adequate ground	Cord is damaged	Replace cord.
	Cord or reel was installed incorrectly	Review installation procedures to identify problem. See SD Cord Reel Installation manual.
	Worn slip-ring /brushes	Replace worn slip-ring/brushes, page 19.
Cord locked when accessory cord was fully extended	Slip-ring cover is assembled in the incorrect position	Relocate slip-ring cover in correct location, page 19.

Problem	Cause	Solution
Breaker or fuse trip out (GFCI accessory or European models only)	Application does not conform to the electrical rating of the reel	Check electrical rating on reel label. Do not attempt to use a reel that is not rated for the application.
	Wires are broken or shorted	Replace all damaged wires.
	GFCI models only: power was removed from unit	Reset GFCI.
Cord could not extend fully	Spring has too much tension applied	Release some of the spring tension. See Decreasing Spring Tension, page 8.

Repair

Replacing the Spring Cassette



Kits❖: 24M452, 24M453, 24M454, 24M455, 24M460, 24M462, 24M463

Reference letters used in the following procedure refer to the kit parts table below and Parts page 26. See Parts pages for additional information regarding kits and their related models.

Ref	Part No.	Description	Qty
100	❖	KIT, spring cassette	1

Disassembly

1. Disconnect cord reel from power source by unplugging main supply plug from outlet.

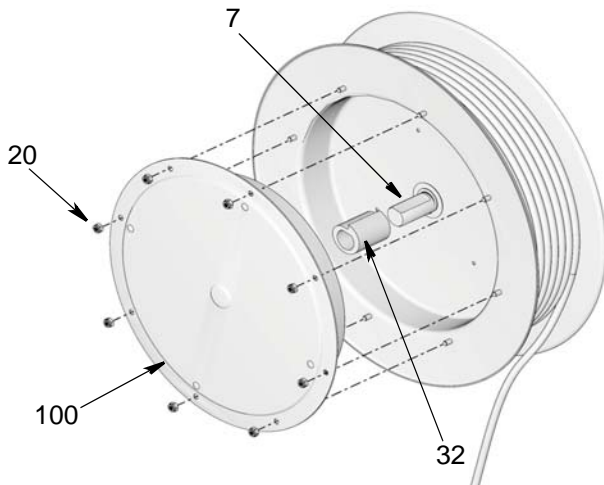

FIG. 2: Size 10 shown

2. Remove spring tension. See Adjusting Spring Tension/Decreasing, page 8.
3. **For Size 5 models:** Loosen the six 10 mm hex nuts (20) and remove spring cassette (FIG. 2).
For Size 10 models: Loosen the eight 10 mm hex nuts (20) and remove spring cassette (FIG. 2).

Reassembly

1. Assemble the hub (32) into the new spring cassette (100) supplied in the kit (FIG. 2).

NOTE: The hook of the spring (a) and the hook of

the hub (b) must maintain the direction as shown in FIG. 3.

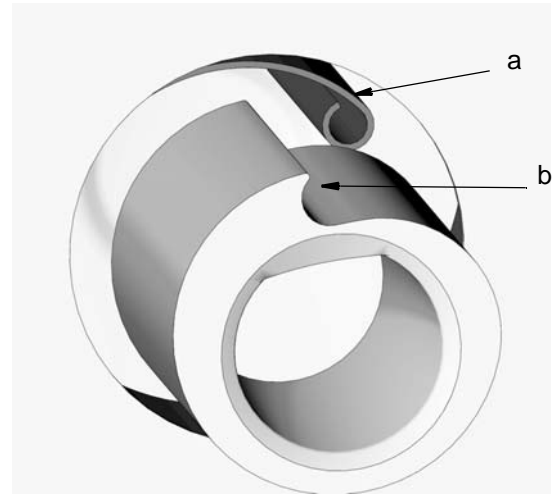

FIG. 3

2. Assemble the spring cassette (100) with the hub (32) onto the shaft (7).

NOTE: When the spring cassette (100) is assembled into the shaft (7) the surfaces (a and b) must be aligned as shown in FIG. 3.

3. **For Size 5 models:** Replace and tighten the six 10 mm hex nuts (20) 26.6 in-lbs (3 N.m) (FIG. 2).
For Size 10 models: Replace and tighten the eight 10 mm hex nuts (20) 26.6 in-lbs (3 N.m) (FIG. 2).
4. Add tension back to reel. See Table 1 on page 8.
5. Plug in cord reel.

Replacing the Accessory Cord

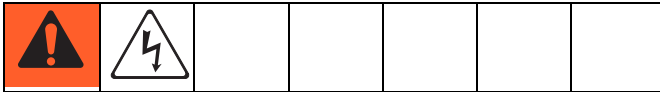

ELECTRIC SHOCK HAZARD

All electrical wiring must be done by a qualified electrician and comply with all local codes and regulations.

Kits†: 24N882, 24N885, 24N886, 24N887, 24N888, 24N889, 24N890, 24N891, 24N892, 24N893, 243N894, 24N895, 24N896

Reference letters used in the following procedure refer to the kit parts table below and Parts page 26. See Parts pages for additional information regarding kits and their related models.

Ref	Part No.	Description	Qty
101	†	KIT, cord replacement, includes	1
101a		CORD,	1
101b		TERMINAL, ring	1
101c		TERMINAL, insulated	1

Disassembly

1. Disconnect cord reel from power source by unplugging main supply plug from outlet.
2. If the cord reel is enclosed, remove enclosures as necessary to access cord reel.
3. Remove spring tension. See Decreasing Spring Tension, page 8.



Never allow the reel to spin freely. Doing so causes the cord reel to spin out of control, which could cause serious injury if you are hit by the plug, accessories or other moving parts

4. Remove remaining cord from spool.
5. Remove ball stop from accessory cord end and put all the parts in a safe place to reinstall on the new cord later (FIG. 4).
 - a. Loosen and remove screws (18) and nuts (19).
 - b. Separate two ball stop components (17) to remove from end of accessory cord.

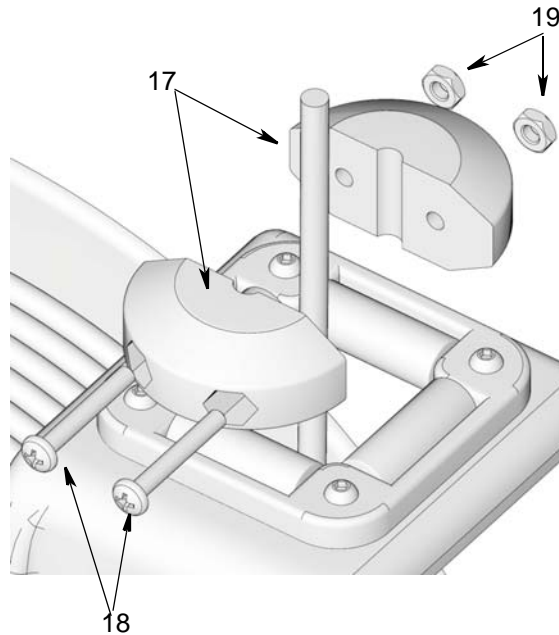

FIG. 4

6. Loosen and remove strain relief nut (5) (FIG. 5) to allow power cord to move freely.

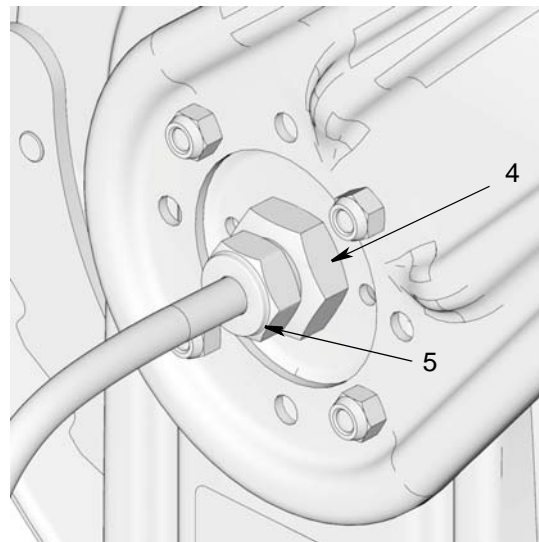





FIG. 5

7. While supporting the spool, loosen 34 mm hex nut (4) (FIG. 4).

						
<p>Take special care not to damage power cord when loosening hex nut. A damaged power cord presents a threat of electric shock and a fire hazard.</p>						

8. Pull spool assembly away from arm and pedestal.
9. **For Size 5 models:** Loosen six 10 mm hex nuts (20) and remove cover (36). (FIG. 6).
For Size 10 models: Loosen eight 10 mm hex nuts (20) and remove cover (36). (FIG. 6).

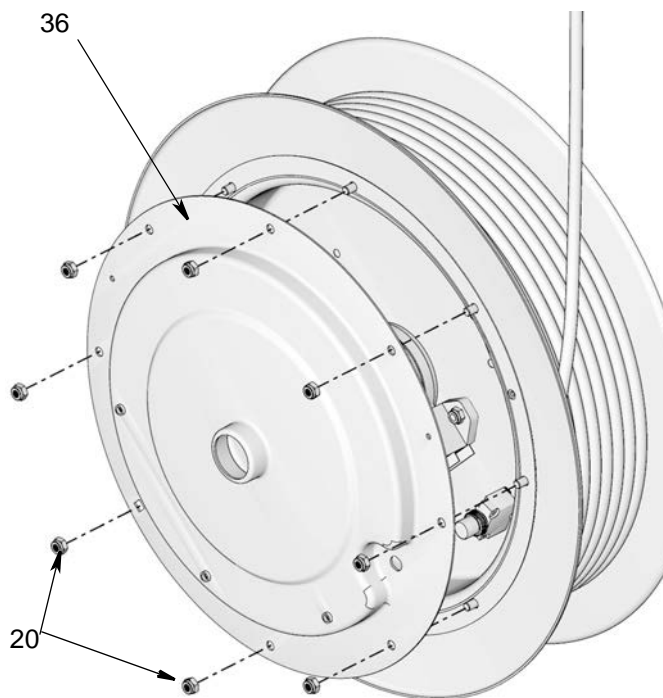

FIG. 6: Size 10 shown

10. Loosen three phillips screws (A) on slip ring brush bracket (22) (FIG. 7).

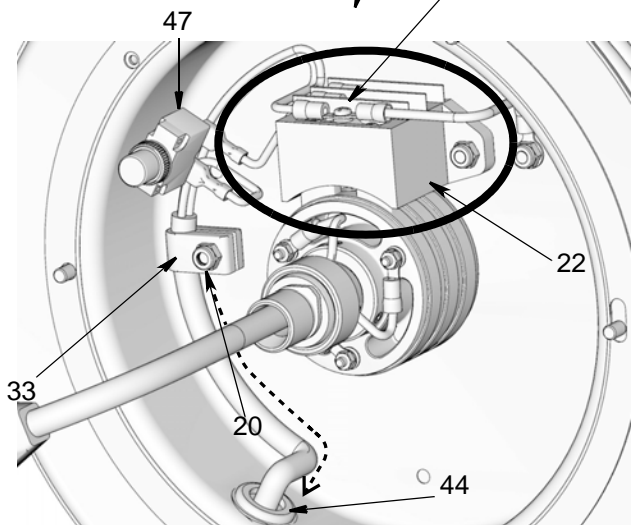
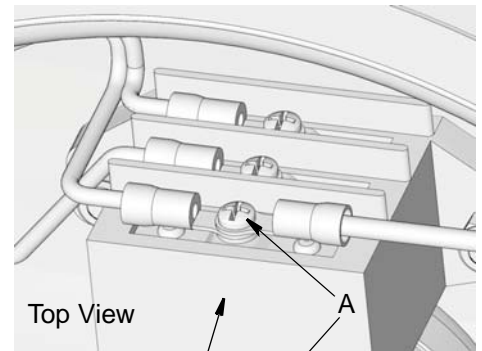

FIG. 7

11. Remove wires from slip ring brush bracket (22) (FIG. 7).

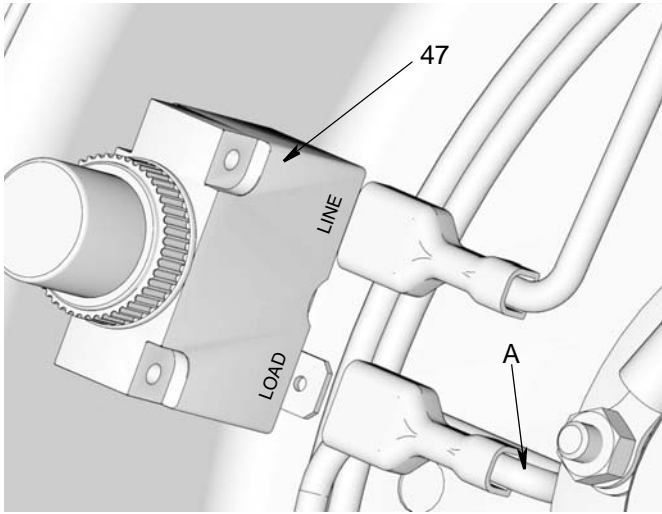

FIG. 8

12. **For 230V models only** disconnect the brown wire (A) from the over current protection device (47). Remove wire from "LOAD" side of device. (FIG. 8)
13. Loosen 10 mm hex nut (20) to relieve tension on cord clamp (33) (FIG. 7).
14. Pull cord back through the grommet (44) in the spool side (FIG. 7).

Reassembly

1. Route new cord (101a) through grommet (44) and cord clamp (33). Tighten 10 mm hex nut to 6 in-lbs (3 N.m) on cord clamp (33) to hold the cord in place securely (FIG. 7, page 13).

NOTE: Ensure there is enough extra cord between cord clamp and slip ring before securing cord clamp (33).

2. **For 230V models,** attach brown wire to over current protection device. (FIG. 8)
3. Attach wires to slip ring brush bracket (22). Refer to Table 2 to ensure the wires are installed in the correct orientation. (FIG. 9)
4. Attach spool ground wire (W) to slip ring brush bracket (22).

	Grounding (X) (W)	Hot (Y)	Neutral (Z)
120V	Green	Black	White
230V	Green-Yellow	Brown	Blue

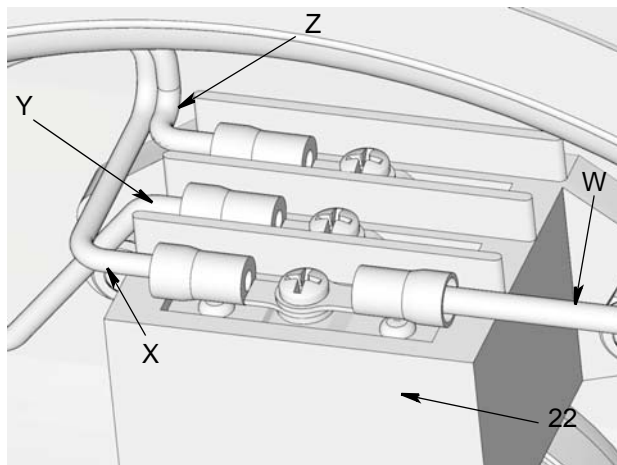

FIG. 9

5. Tighten to 10.2 in-lbs (1.15 N.m) with phillips screws on slip ring brush bracket (22).
6. Ensure gasket (34) is in place. Refer to FIG. 10 for correct placement.

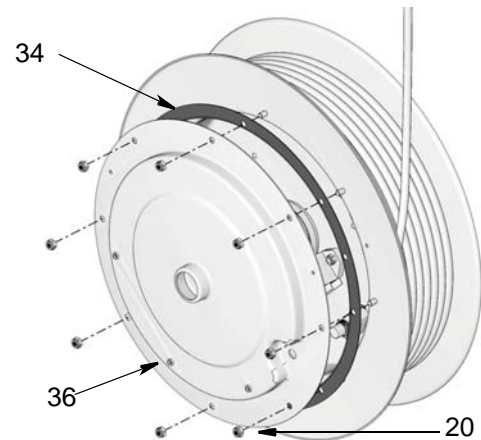

FIG. 10: Size 10 shown

7. Reassemble cover (36).
8. **For Size 5 models:** Tighten six 10mm hex nuts (20) to 26.6 in-lbs (3 N.m).
For Size10 models: Tighten eight 10mm hex nuts (20) to 26.6 in-lbs (3 N.m).
9. With accessory cord secured to the spool, wrap all the cord around the spool. Wrap cord in a clockwise direction when looking at the spring cassette. (FIG. 11)



FIG. 11: Size 10 shown

- Mount spool assembly into arm and pedestal taking care to ensure keyed shaft aligns with arm and pedestal. Ensure washer is in place as shown in FIG. 12.

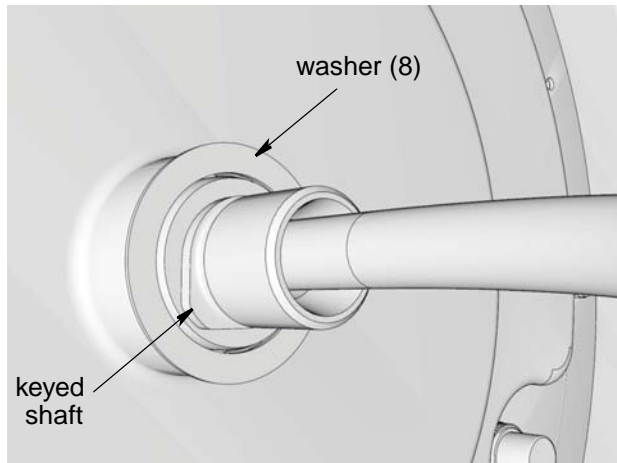

FIG. 12

- Tighten 34 mm hex nut (4) to 59 ft-lbs (80 N.m). (Refer to FIG. 5, page 12 for the location of this part.)

Take special care not to damage power cord when loosening hex nut. A damaged power cord presents a threat of electric shock and a fire hazard.						

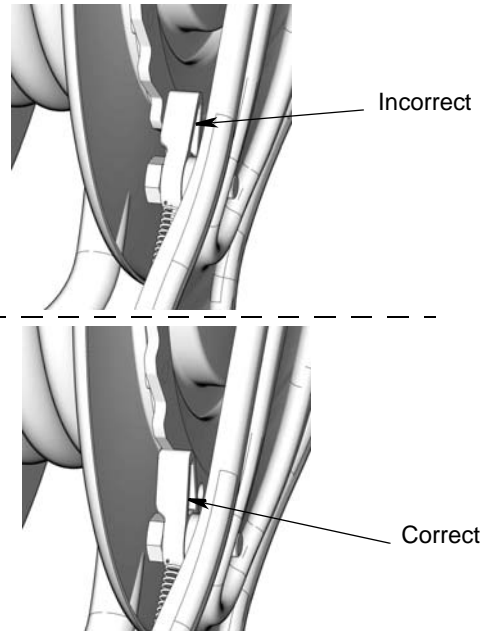

FIG. 13

- Check pawl to make sure it is not wedged (FIG. 13).
- Tighten strain relief nut (5) to 11 ft-lbs (15 N.m). (Refer to FIG. 5, page 12 for the location of this part.)
- Route accessory cord through roller guide.
- Position the two ball stop (17) halves around cord. Insert screws (18) through ball stop and hand tighten nuts (19) to hold ball stop in place. (FIG. 4, page 12)
- Adjust spring tension. See Adjusting Spring Tension, page 8.
- Install accessory to end of accessory cord. See appropriate section of this manual for accessory installation.
- If used, reassemble cord reel enclosure following procedure described in the SD Reel Enclosure Installation Instruction manual.

Electrical Power Cords



ELECTRIC SHOCK HAZARD

All electrical wiring must be done by a qualified electrician and comply with all local codes and regulations.

Kits♦: 24N866, 24N867, 24N868, 24N869, 24N870

Reference letters used in the following procedure refer to the kit parts table below and Parts page 26. See Parts pages for additional information regarding kits and their related models.

Ref	Part No.	Description	Qty
102	♦	KIT, power cord, includes	1
102a		CORD	1
102b		PLUG (included in 24N868 and 24N869)	1
102c		TERMINAL, ring	3
102d		STOP, cord gland	1
102e		LABEL, safety (only on 120V models)	1
102f		LABEL, safety (only on 120V models)	1
102g		LABEL, safety (only on 120V models)	1

Disassembly

1. Disconnect cord reel from power source by unplugging main supply plug from outlet.
2. Continue disassembly procedure for Replacing the Accessory Cord Instructions, Steps 2 - 9, pages 12 - 13.
3. Loosen and remove three 7 mm hex nuts (A) and lockwashers (B) from slip ring (21) (FIG. 14).

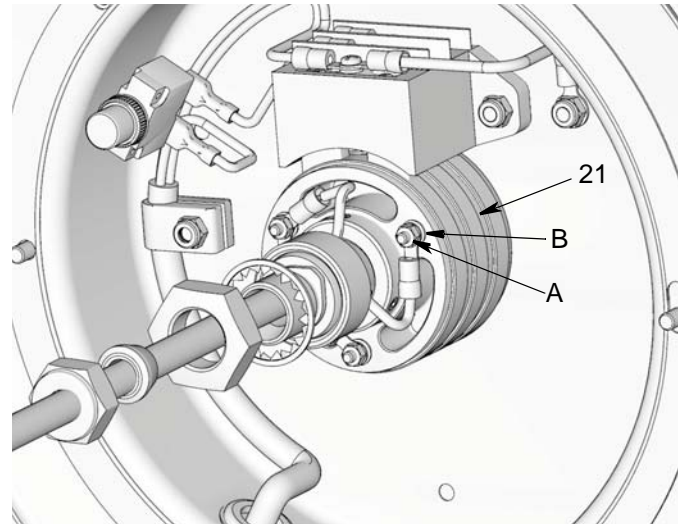

FIG. 14

4. Cut wire at ring terminals (43). (FIG. 15)

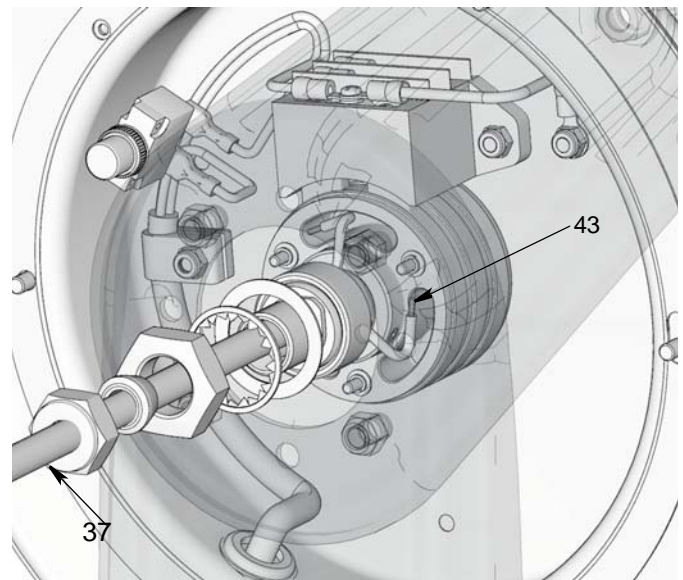

FIG. 15

5. Remove power cord (37). (FIG. 15)

Reassembly

1. Route power cord (102a) through strain relief nut (5), cord stop (102d), 34 mm hex nut (4), star washer (27) through pedestal arm, washer (8), and then through shaft (7). (FIG. 16)

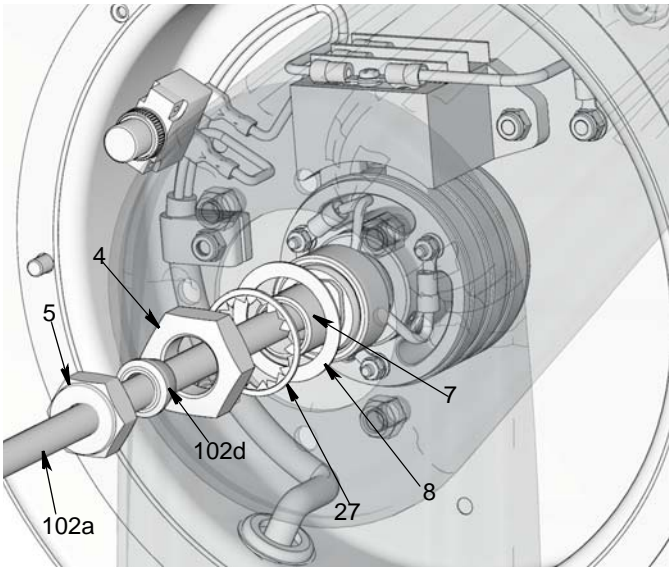

FIG. 16

2. Orient cord so wires route to appropriate holes and to the left side of the desired mounting stud as shown in FIG. 17 and Table 3.

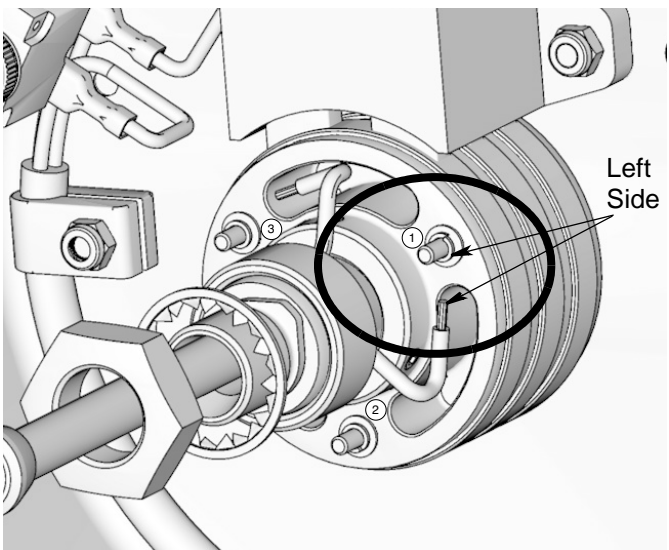

FIG. 17

3. Use new ring terminals (102c) from kit and crimp onto each conductor of the cord.

NOTE: Test each crimp by performing a pull test on each conductor to ensure proper crimp.

4. Mount terminal rings (102c) to appropriate mounting stud as shown in FIG. 18. Refer to Table 3 for wire locations.

	Grounding	Hot	Neutral
	1*	2*	3*
120V	Green	Black	White
230V	Green/Yellow	Brown	Blue

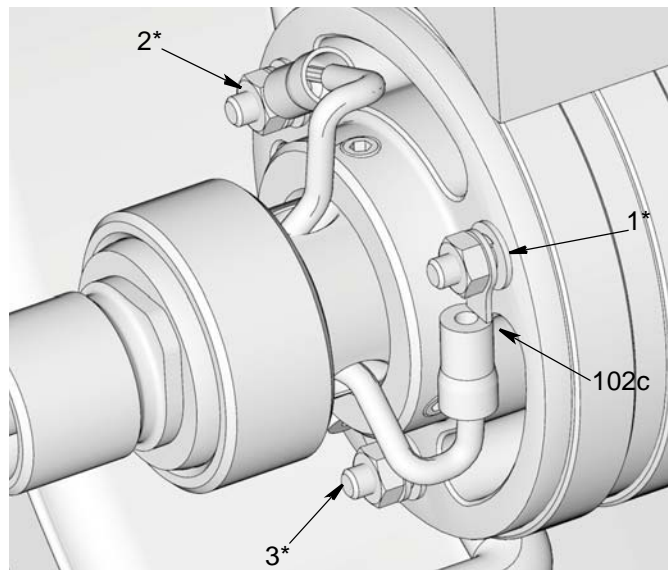

FIG. 18

5. Install three lock washers (B) and three 7 mm hex nuts (A). Tighten nuts to 10.2 in-lbs (1.15 N.m). (FIG. 19)

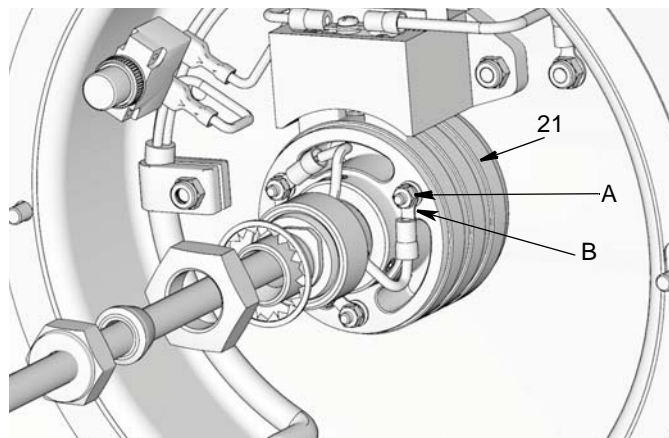

FIG. 19

- Continue reassembly procedure for Replacing the Cord Instructions, Steps 7 - 18, page 15.

Slip Ring Replacement

Reference letters used in the following procedure refer to the kit parts table below and Parts page 26. See Parts pages for additional information regarding kits and their related models.

Ref	Part No.	Description	Qty
103	24N687	KIT, slip ring and brush	1
103a		RING, slip	1
103b		BRACKET, carbon brush	1
103c		TOOL, assembly, repair, slip ring	1

Disassembly

Slip Ring Brush Bracket

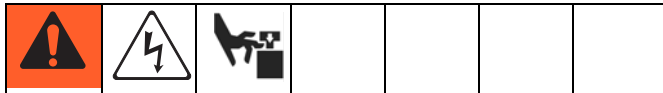

- Disconnect cord reel from power source by unplugging main supply plug from outlet.
- Continue disassembly procedure for Replacing the Accessory Cord Instructions, Steps 2 - 13, pages 12 - 13
- Disassemble two 10 mm hex nuts (20) holding slip ring brush bracket (22) to slip ring (21). Remove slip ring brush bracket. (FIG. 20)

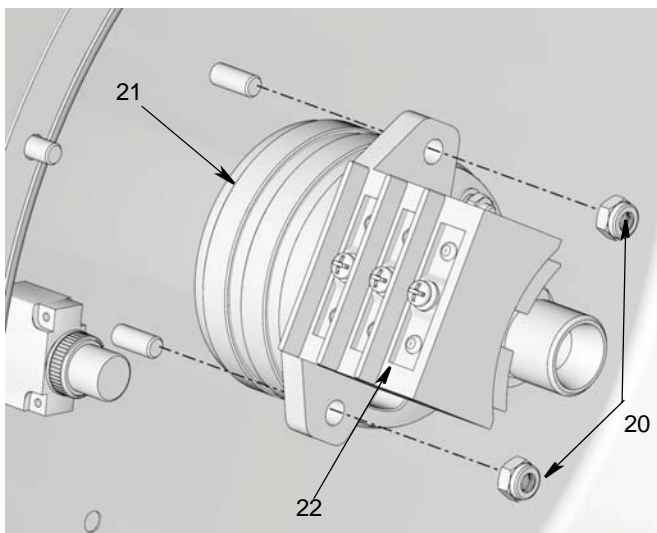

FIG. 20

Slip Ring

- In order to remove slip ring (21), disassembly of spring cassette is required. Remove spring cassette. Continue Disassembly with Steps 1-3 of the Replacing the Spring Cassette section on page 11 of this manual.
- Remove retaining clip (25).

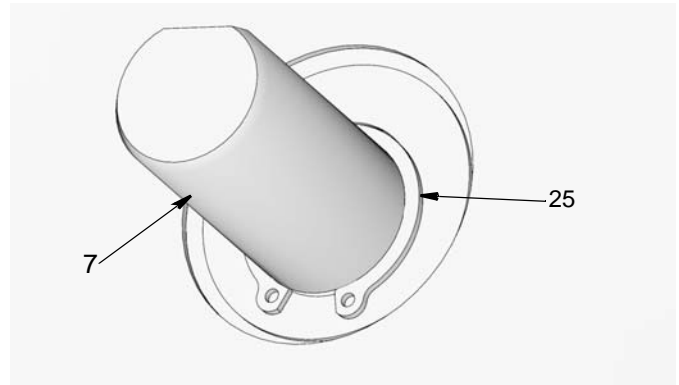

FIG. 21

- Slide shaft (7) out of spool.
- Loosen two set screws (A) and grounding lug on shaft (7). (FIG. 22)
- Slide slip ring off of the shaft.

Reassembly

- Insert the slip ring (103a) onto shaft (7) (FIG. 22).

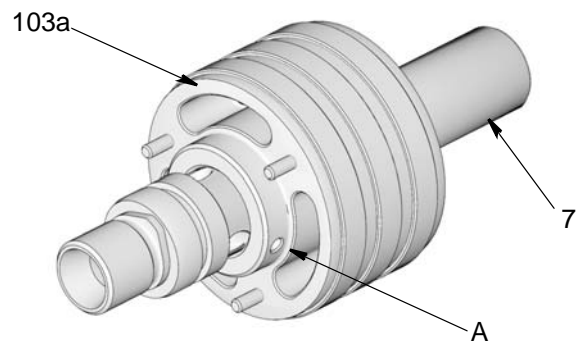

FIG. 22

2. Align set screw holes (A) on shaft (7) with proper holes on new slip ring. Tighten set screw to hand tight.
3. Re-install ground lug and wire between position 1 on slip ring and ground lug on shaft (7).
4. Re-install retaining clip (25) onto shaft (7) and slip ring (103a) in place. (FIG. 21)
5. Press tool (103c) onto the slip ring brush bracket (103b) as shown in FIG. 23.

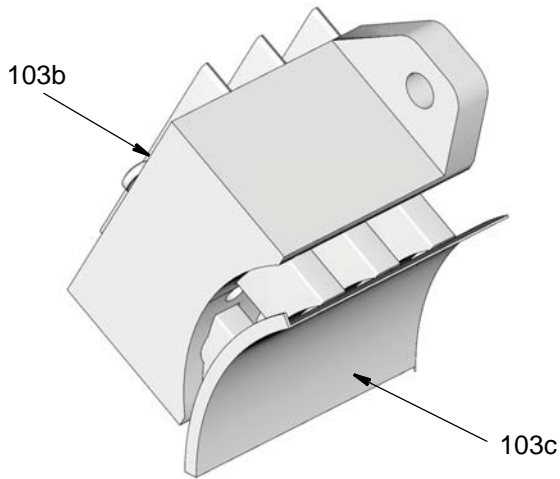

FIG. 23

6. Install slip ring brush bracket (103b) onto spool. Tighten two 10 mm hex nuts (20) to 26.6 in-lbs (3 N.m).

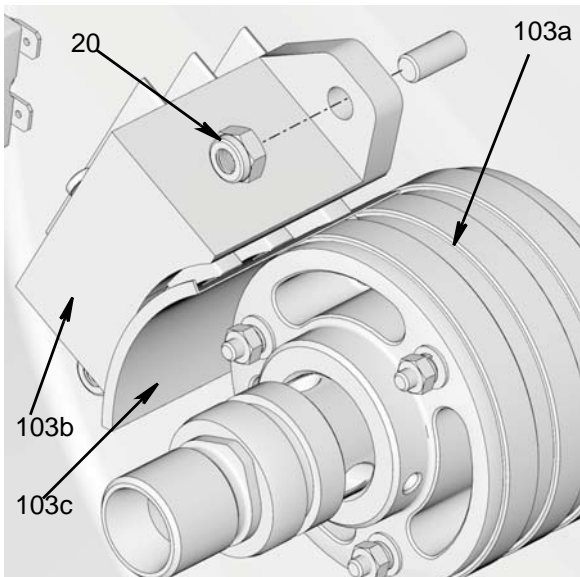

FIG. 24

7. Remove tool (103c) from assembly (FIG. 25).

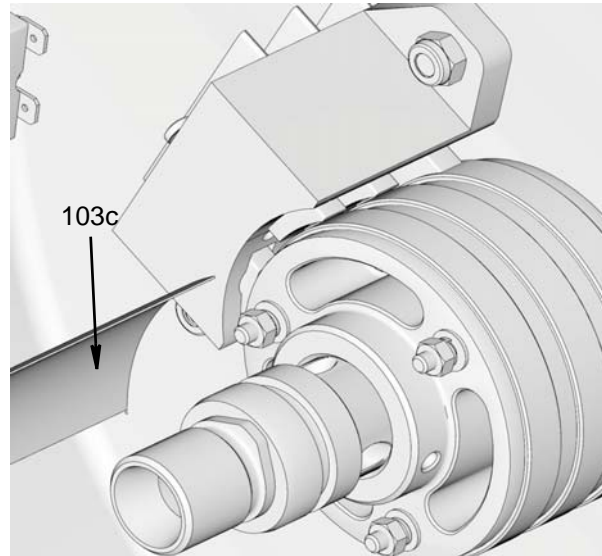

FIG. 25

8. Continue Reassembly with Steps 3 - 18 of the Replacing the Accessory Cord section, beginning on page 15 of this manual.

Single Industrial Receptacle

120V Models NEMA 5-20R (24N871)

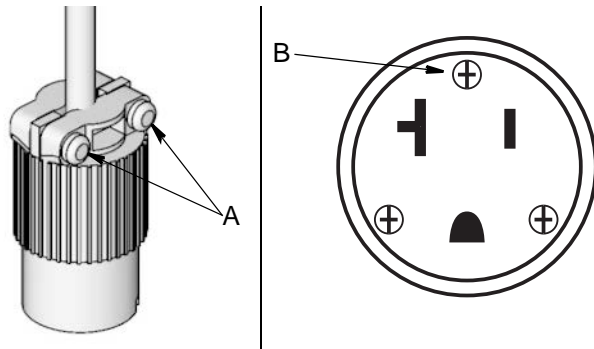

FIG. 26

Disassembly

1. Disconnect cord reel from power source by unplugging main supply plug from outlet.
2. Loosen strain relief screws (A) from plug attached to reel. (FIG. 26)
3. Loosen three screws (B) (FIG. 26) on the front of the receptacle.
4. Remove receptacle from housing to expose wiring terminals.
5. Loosen three wiring terminal screws and remove wires.
6. Slide housing over cord.

Reassembly

1. If cord is not stripped, strip wire on cord 1/4" (6.35 mm).
2. Place green ground wire in position 1 (a) with green ground screw (FIG. 27). Tighten green screw.
3. Place white wire in position 2 (b) with silver screw (FIG. 27). Tighten silver screw.
4. Place black wire in position 3 (c) with brass screw (FIG. 27). Tighten brass screw.

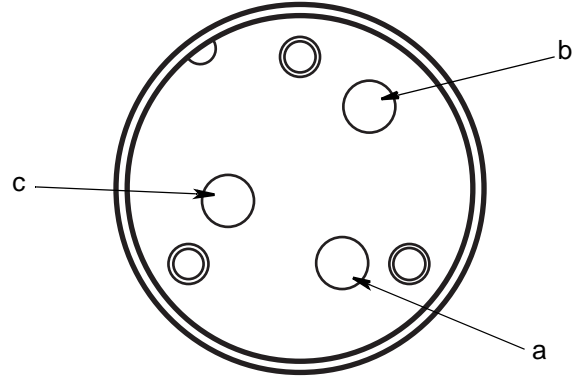

FIG. 27: Viewed from the back

5. Slide receptacle into housing.
6. Replace and tighten 3 screws on front of receptacle.
7. Install strain relief and tighten screws.
8. Plug reel back in and test.

230 Models CEE 7/7 16 Receptacle (24N872)

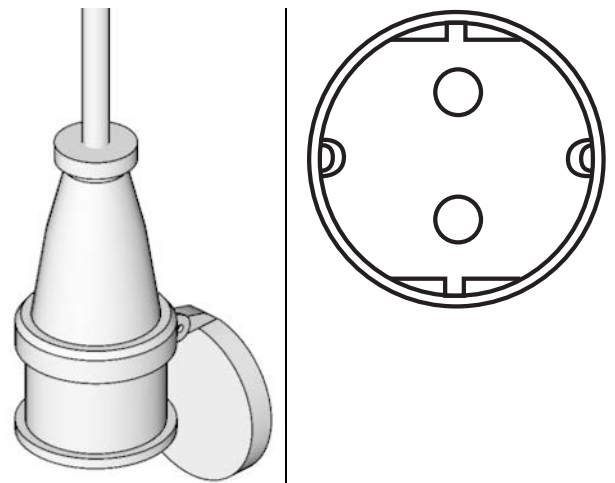
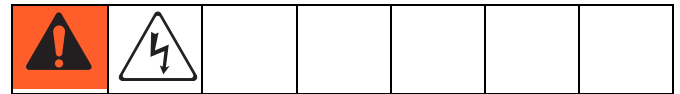

FIG. 28

Disassembly

1. Disconnect cord reel from power source by unplugging main supply plug from outlet.
2. Loosen the phillips screw located in the center of the plug.
3. Pull outer protective shell back to expose wiring terminals.

4. Loosen two phillips screws for strain relief.
5. Loosen three screws to wire terminals. Remove wire.

Reassembly

1. Route wire through protective shell.
2. Install brown wire in left wiring terminal and tighten screw.
3. Install green/yellow wire in center wiring terminal and tighten screw.
4. Install blue wire in right wiring terminal and tighten screw.
5. Tighten down strain relief.
6. Slide protective shell over terminals and reinstall phillips screw.

Fluorescent Light (16N223)

For repair instructions, see instructions provided with light.



FIG. 29

Fluorescent Light with Tool Tap (16N224)

For repair instructions, see instructions provided with light.



FIG. 30

LED Light 120V (127088)

For repair instructions, see instructions provided with light.



FIG. 31

LED Light 230V (16N225)

For repair instructions, see instructions provided with light.



FIG. 33

Tool Tap 120V (16N226)

For repair instructions, see instructions provided with light.

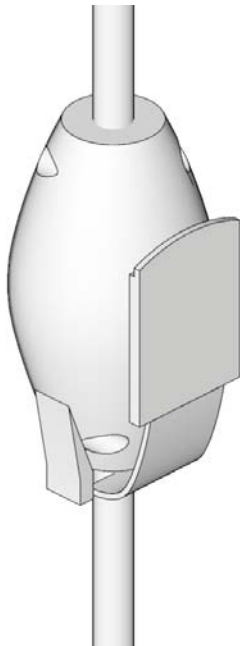

FIG. 32

Tri-Plug GFCI Industrial Receptacle(24N880)



Disassembly

1. Disconnect cord reel from power source by unplugging main supply plug from outlet.
2. Loosen two Phillips #2 screws (A) on GFCI cover (B). Remove cover (FIG. 34).

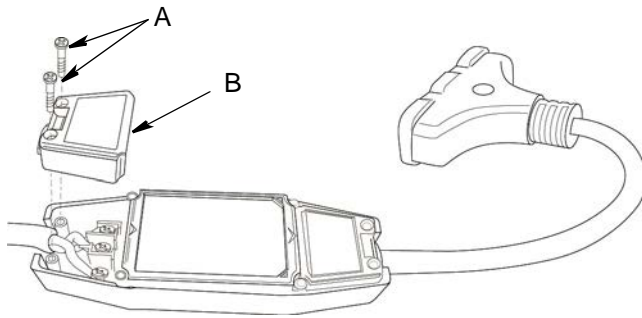

FIG. 34

3. Unscrew three Phillips #2 screws (C) and disconnect black, white, and green wires from GFCI terminals (FIG. 35).

NOTE: Instructions for installing cord reel in enclosure are included in the **Hose or Cord and Light Reel Enclosure** instruction manual.

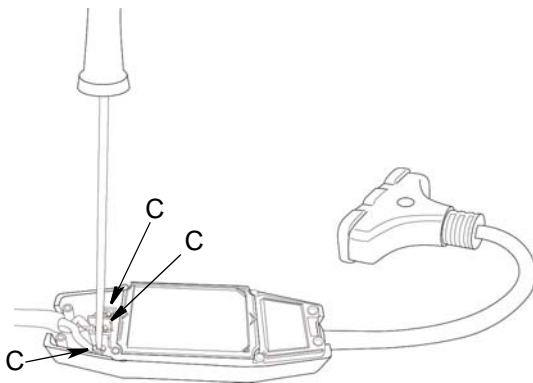

FIG. 35

Reassembly

1. Route cord through enclosure panel and through opening in roller guide.
2. Connect green wire from cord to green terminal from GFCI module. Connect black wire from cord to silver terminal. Connect white wire from cord to brass terminal. Re-tighten three Phillips #2 screws (C) (FIG. 35).
3. Reassemble GFCI cover (B) with two Phillips #2 screws (A) (FIG. 34).
4. Reconnect power source.
5. Press TEST button to test the GFCI.

Replacement Bulbs For Fluorescent Lights - 16P697

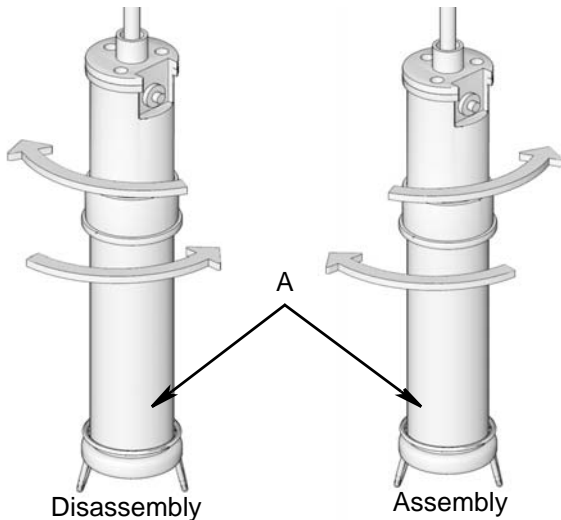

FIG. 36

Disassembly

1. Disconnect cord reel from power source by unplugging main supply plug from outlet.
2. Twist diffuser (A) in a counter clockwise direction.
3. Remove light bulb from diffuser.

Reassembly

1. Install light bulb in diffuser.
2. Twist diffuser in clockwise direction onto light.
3. Ensure light bulb plugs into socket by visual inspection.
4. Plug reel back in and test.

For 230V LED Lights - 16P1696



FIG. 37

Disassembly

1. Disconnect cord reel from power source by unplugging main supply plug from outlet.
2. Slide black handle off.
3. Remove the two screws.
4. Slide diffuser off.
5. Remove light bulb. Dispose of light bulb according to applicable guidelines.

Reassembly

1. Install light bulb in socket.
2. Slide diffuser into place over bulb until holes line up.
3. Tighten two screws to secure diffuser.
4. Slide black handle back over handle.
5. Plug reel back in and test.

Parts Size 5 shown

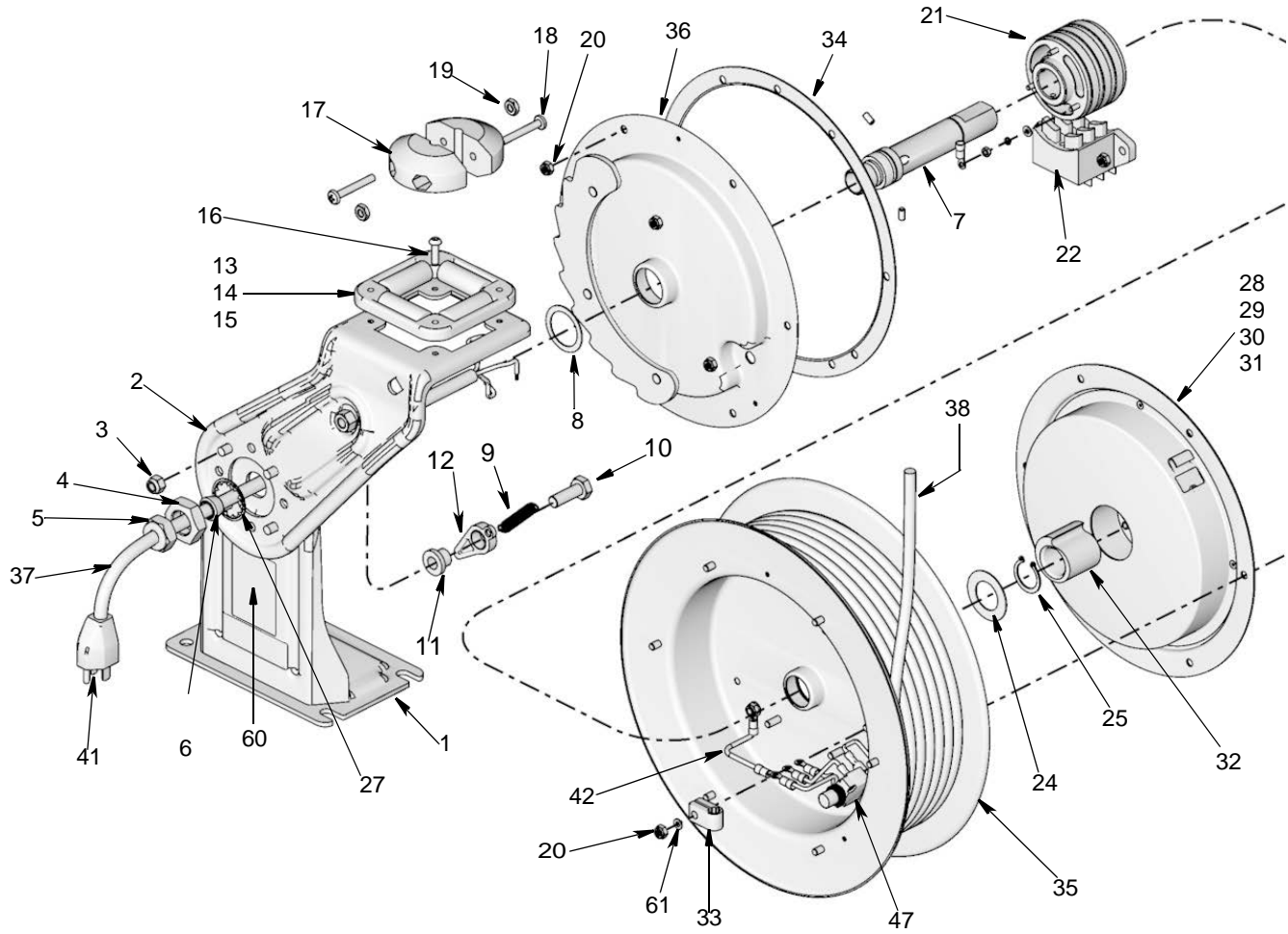

Size 5 and Size 10 Models

See page 29 for a complete list of kits referenced in the following parts table.

REF	Kit No.	Description	Qty
1		BASE, welded, Size 5 models	1
		BASE, welded, Size 10 models	1
2		ARM, guide, Size 5 models	1
		ARM, guide, Size 10 models	1
3		NUT, lock	4
4		NUT, M22 x 1.5 MM	1
5		CAP, wire, M22 x 1.5, 16 AWG, and 1.5 mm ² models 24M510, 24M511, 24M514, 24M515, 24M517, 24M518, 24M527 - 24M543, 24Y858, 24Y860, 24Y861, 24Y865, 24Y879, 24Y884 - 24Y887, 24Y890	1
		CAP, wire, M22 x 1.5, 12 AWG and 2.5 mm ² , models 24M512, 24M513, 24M516, 24M521, 24M522, 24Y859, 24Y862, 24Y864, 24Y880, 24Y883, 24Y888, 24Y889	1
		CAP, wire, M22 x 1.5, 12 AWG and 1.5 mm ² , models 24M523, 24M524, 24N525, 24M526, 24M544,	
6	106a 107a	STOP, cord, gland, 16 AWG and 1.5 mm ² models, 24M510, 24M511, 24M514, 24M515, 24M517, 24M518, 24M527 - 24M543, 24Y858, 24Y860, 24Y861, 24Y865, 24Y879, 24Y884 - 24Y887, 24Y890	1
	106b 107b	STOP, cord, gland, 12 AWG and 2.5 mm ² , models 24M512, 24M513, 24M516, 24M521, 24M522, 24M523, 24M524, 24N525, 24M526, 24M544, 24Y859, 24Y862 - 24Y864, 24Y880 - 24Y883, 24Y888, 24Y889	1
7		SHAFT, cord reel, Size 5 models	1
		SHAFT, cord reel, Size 10 models	
8		WASHER, flat 31 ID	1

REF	Kit No.	Description	Qty
9	105a	SPRING, ratchet pawl	1
10	105b	BOLT, M10 x 25 lg w patch	1
11	105c	BUSHING, pawl	1
12	105d	PAWL, ratchet	1
13	108a	BRACKET, roller	1
14	108b	ROLLER	4
15	108c	PIN, roller	4
16	108d	SCREW, M6 x 16	4
17	109c	STOP, cord, 16 AWG, and 1.5 mm ² , models 24M510, 24M511, 24M514, 24M515, 24M517, 24M518, 24M527 - 24M543, 24Y858, 24Y860, 24Y861, 24Y865, 24Y879, 24Y884 - 24Y887	2
	109c	STOP, cord, 12 AWG, 2.5 mm ² , models 24M512, 24M513, 24M516, 24M521, 24M522, 24M523, 24M524- 24M526, 24M544, 24Y859, 24Y862 - 24Y864, 24Y880 - 24Y883, 24Y888, 24Y889	2
18	109b	SCREW, machine, pnh	2
19	109a	NUT, hex, jam,	2
20		NUT, hex, 10 mm, non-metallic insert, Size 5 models	16
		NUT, hex, 10 mm, non-metallic insert, Size 10 models	20
21	103a	RING, slip	1
22	103b	BRACKET, carbon, brush	1
23		SCREW, setting, M5 x10, not shown	2
24		WASHER, flat, spring side	1
25		RING, retaining	1
27		WASHER, with internal teeth	1
28	100	COVER, spring, black, not shown	1
29	100	CASSETTE, spring, black, not shown	1
30	100	SPRING, power, not shown,	1

REF	Kit No.	Description	Qty
31	100	RIVET, aluminum, 4mm, not shown	4
32		HUB, cord reel, 3550, Size 5 models	1
		HUB, cord reel, 7500, Size 10 models	1
33	106g 107g	CLAMP, wire, 12 AWG, models 24M512, 24M513, 24M521 - 24M526, 24Y859, 24Y862 - 24Y864, 24Y880 - 24Y883	1
	106h 107h	CLAMP, wire, 16 AWG, 1.5 mm ² , models 24M510, 24M511, 24M514, 24M515, 24M517, 24M518, 24M527-24M543, 24Y858, 24Y860, 24Y861, 24Y865-24Y879, 24Y884--24Y887, 24Y890	1
34	106d	SEAL, spool, Size 5 models	1
	107d	SEAL, spool, Size 10 models	1
35		FLANGE, set, black, Size 5 models	1
		FLANGE, set, black, Size 10 models	1
36		COVER, assembly, slip ring, Size 5, models 24M510, 24M512, 24M517, 24M518, 24M521, 24M522, 24M525, 24M527, 24M528, 24M530, 24M531, 24M533, 24M534, 24M536, 24M537, 24Y858-24Y872	1
		COVER, assembly, slip ring, Size 5, black, models 24M514, 24M515, 24M539, 24M540, 24M542, 24M543, 24Y873-24Y878	1
		COVER, assembly, slip ring, Size 10, metallic blue, 24M511, 24M513, 24M523, 24M524, 24M526, 24M529, 24M532, 24M535, 24M538. 24Y879-24Y887	1
		COVER, assembly, slip ring, Size 10, black, 24M516, 24M541, 24M544, 24Y888-24Y890	1
37	102a	CORD, power	1
38	101a	CORD, accessory	1
39	106c 107c	PACKING, o-ring, not shown,	1

REF	Kit No.	Description	Qty
40	106e 107e	GROMMET, diaphragm, 12 AWG, 2.5 mm ² , not shown, models 24M512, 24M513 24M516, 24M521, 24M522, 24M523, 24M524, 54M525, 24M526, 24M544, 24Y859, 24Y862 - 24Y864, 24Y880 - 24Y883, 24Y888, 24Y889	1
	106f 107f	GROMMET, diaphragm, 16 AWG, 1.5 mm ² , not shown, models 24M510, 24M511, 24M514, 24M517, 24M518, 24M527 - 24M543, 24Y858, 24Y860, 24Y861, 24Y865 - 24Y879, 24Y884 - 24Y887, 24Y890	1
41	102b	PLUG, NEMA, 5-20P, 12AWG, 120V, models 24M512, 25M513, 24M521, 24M522, 24M523, 24M524, 24N525, 24M526, 24Y859, 24Y880-24Y883, 24Y862-24Y864	1
	102b	PLUG, CEE 7/7, 2.5 mm ² , model 24M544, 24Y889	1
42		CORD, grounding with terminals	1
43	102c*	TERMINAL, ring, M4, 16 AWG, 1.5 mm ² , not shown, models 24M510, 24M511, 24M514, 24M515, 24M517, 24M518, 24M527 - 24M543, 24Y858, 24Y860, 24Y861, 24Y865-24Y879, 24Y884-24Y887, 24Y890	5
	102c*	TERMINAL, ring, M4, 12 AWG, 2.5 mm ² , M4, not shown, models 24M512, 24M513, 24M516, 24M521-24M526, 24M544, 24Y859, 24Y862-24Y864, 24Y880-24Y883, 24Y888, 24Y889	7
* Kit 102c contains a quantity of 3. Quantity shown reflects the total number of terminal rings used on assembly.			
44		TERMINAL, insulated, 1.5 mm ² -2.5 mm ² not shown, models 24M514 - 24M516, 24M539 - 24M544, 24Y873-24Y878, 24Y888-24Y890	1

REF	Kit No.	Description	Qty
45	24N871	SOCKET, single, NEMA, 5-20R, not shown, models 24M521-24M524, 24Y862, 24Y863, 24Y881, 24Y882	1
46		CORD, protector-to-carbon brush, not shown, models 24M514-24M516, 24M539-24M544, 24Y873-24Y878, 24Y888-24Y890	1
47		PROTECTOR, thermal, cord reel, 10A, models 24M514-24M515, 24M539 - 24M543, 24Y873-24Y878, 24Y890	1
		PROTECTOR, thermal, cord reel, 2.5 mm ² , models 24M516, 24M544, 24Y888, 24Y889	1
49		TERMINAL, ring M4, 16 AWG and 1.5 mm ² , not shown, models 24M510, 24M511, 24M514, 24M515, 24M517, 24M518, 24M527 - 24M543, 24Y858, 24Y860, 24Y861, 24Y865-24Y879, 24Y884-24Y887, 24Y890	1
50		TERMINAL, ring, M6, 12 AWG, 2 mm ² , not shown	1
60		LABEL, brand	1
61		WASHER	1
62 ▲	16P224	TAG, danger, cord reel, English	1
63 ▲	16P392	TAG, danger, cord reel, French	1
64 ▲	169394	TAG, danger, cord reel, Spanish	1
65 ▲	16P454	LABEL, safety, multiple	1

▲ Replacement Danger and Warning labels, tags, and cards are available at no cost.

Kits

Ref	Part No.	Description	Qty
100	24M452	KIT, spring cassette, Size 5, models 24M518, 24Y861	
	24M453	KIT, spring cassette, Size 5 models 24M514, 24M517, 24M527, 24M530, 24M533, 24M536, 24M539, 24M542, 24Y860, 24Y865, 24Y867, 24Y869, 24Y871, 24Y873, 24Y875, 24Y877,	
	24M454	KIT, spring cassette, Size 5 models 24M512, 24M522, 24M525, 24Y859, 24Y863, 24Y864	
	24M455	KIT, spring cassette, Size 5 models 24M510, 24M515, 24M518, 24M528, 24M531, 24M534, 24M537, 24M540, 24M543, 24Y858, 24Y861, 24Y866, 24Y868, 24Y870, 24Y872, 24Y874, 24Y876, 24Y878	
	24M462	KIT, spring cassette, Size 10 models 24M513, 24M516, 24M523, 24M524, 24M526, 24M544, 24Y880-24Y883, 24Y888, 24Y889	
	24M463	KIT, spring cassette, Size 10 models 24M511, 24M529, 24M532, 24M535, 24M538, 24M541, 24Y879, 24Y884 - 24Y887, 24Y890,	

Ref	Part No.	Description	Qty
101	24N882	KIT, cord, 1.5 mm ² , 25 M, models 24M541, 24Y890	1
	24N885	KIT, cord, 50 feet, 16 AWG, SJTOW, models 24M510, 24M528, 24M531, 24M534, 24M537, 24Y858, 24Y866, 24Y868, 24Y870, 24Y872	1
	24N886	KIT, cord, 95 feet, 16 AWG, SJTOW, models 24M511, 24M529, 24M532, 24M535, 24M538, 24Y879, 24Y884, 24Y887	1
	24N887	KIT, cord, 50 feet, 12 AWG, SJOOW, models 24M512, 24M522, 24M525, 24Y859, 24Y863, 24Y864	1
	24N888	KIT, cord, 95 feet, 12 AWG, SJOOW, models 24M513, 24M524, 24M526, 24Y880, 24Y882, 24Y883	1
	24N889	KIT, cord, 1.5 mm ² , 10 M, models 24M514, 24M539, 24M542, 24Y873, 24Y875, 24Y877	1
	24N890	KIT, cord, 1.5 mm ² , 15 M, models 24M515, 24M540, 24M543, 24Y874, 24Y876, 24Y878	1
	24N891	KIT, cord, 2.5 mm ² , 25M, models, 24M516, 24M544, 24Y888, 24Y889	1
	24N892	KIT, cord, 35 feet, 16 AWG, SJTOW with NEMA 5-15R, models 24M517, 24Y860	1
	24N893	KIT, cord, 50 feet, 16 AWG, SJTOW with NEMA 5-15R, models 24M518, 24Y861	1
	24N894	KIT, cord, 35 feet, 12 AWG, SJOOW, models 24M521, 24Y862	1
	24N895	KIT, cord, 75 feet, 12 AWG, SJOOW, models 24M523, 24Y881	1
	24N896	KIT, cord, 35 feet, 16AWG, SJTOW, models 24M527, 24M530, 24M533, 24M536, 24Y865, 24Y867, 24Y869, 24Y871	1

Ref	Part No.	Description	Qty
101a		CORD	1
101b		TERMINAL, ring	1
101c		TERMINAL, insulated	1
102	24N866	KIT, power cord, NEMA 5-15P, 16 AWG, models 24M510, 24M511, 24M517, 24M518, 24M527 - 24M538, 24Y858, 24Y860, 24Y861, 24Y865-24Y872, 24Y879, 24Y884-24Y887	1
	24N867	KIT, power cord, CEE 7/7, 1.5 mm ² , models 24M539 - 24M543, 24Y875-24Y890	1
	24N868	KIT, power cord, NEMA, 5-20P, 12 AWG, models 24M512, 24M513, 24M521, 24M522, 24M523, 24M524- 24M526, 24Y859, 24Y862,-24Y864, 24Y880-24Y883	1
	24N869	KIT, power cord, CEE 7/7, 2.5 mm ² , models 24M516, 24M544	1
	24N870	KIT, power cord, 1.5 mm ² , models 24M514, 24M515m 24Y873, 24Y874	1
	102a		CORD
102b		PLUG, included in 24N868 and 24N869	1
102c		TERMINAL, ring	3
102d		STOP, cord gland	1
102e		LABEL, safety, only on 120V models	1
102f		LABEL, safety, only used on 120V models	1
102g		LABEL, safety, only used on 120V models	1
103	24N687	KIT, slip-ring	
103a		RING, slip	1
103b		BRACKET, carbon, brush	1
103c		TOOL, assembly, repair, slip ring (not shown)	1
104	24N880	KIT, socket, assembly, GFCI 5-15R	
104b		SOCKET, Tri-Plug	1
104c		MODULE, GFCI, 125V,15A	1
105	15Y503	KIT, latch, repair	
105a		SPRING, ratchet pawl	1
105b		BOLT, M10 x 25 lg w patch	1

Ref	Part No.	Description	Qty
105c		BUSHING, pawl	1
105d		PAWL, ratchet	1
105e		NUT, lock	1

106	24N540	KIT, seal and wire clamping, Size-5	
106a		STOP, cord, gland, 16 AWG and 1.5 mm ² , models 24M510, 24M514, 24M515, 24M517, 24M518, 24M527, 24M528, 24M530, 24M531, 24M533, 24M534, 24M536, 24M537, 24M539, 24M540, 24M542, 24M543, 24Y858, 24Y860, 24Y861, 24Y865-24Y878	1
106b		STOP, cord, gland, 12 AWG, models 24M512, 24M521, 24M522, 24M525, 24M859, 24Y862-24Y864	1
106c		PACKING, o-ring	1
106d		SEAL, spool, Size 5 models	1
106e		GROMMET, diaphragm, 12 AWG, models 24M512, 24M521, 24M522, 24M525, 24M859, 24Y862-24Y864	
106f		GROMMET, diaphragm, 16 AWG, 1.5 mm ² , models 24M510, 24M514, 24M515, 24M517, 24M518, 24M527, 24M528, 24M530, 24M531, 24M533, 24M534, 24M536, 24M537, 24M539, 24M540, 24M542, 24M543, 24Y858, 24Y860, 24Y861, 24Y865-24Y878	1
106g		CLAMP, wire, 12 AWG, 2.5 mm ² , models 24M512, 24M521, 24M522, 24M525, 24M859, 24Y862-24Y864	

Ref	Part No.	Description	Qty
106h		CLAMP, wire, 16 AWG, 1.5 mm ² , models 24M510, 24M514, 24M515, 24M517, 24M518, 24M527, 24M528, 24M530, 24M531, 24M533, 24M534, 24M536, 24M537, 24M539, 24M540, 24M542, 24M543, 24Y858, 24Y860, 24Y861, 24Y865-24Y878	1
107	24N541	KIT, seal and wire clamping, Size-10	
107a		STOP, cord, gland, 16 AWG, 1.5 mm ² , models 24M511, 24M529, 24M532, 24M535, 24M538, 24M541, 24Y879, 24Y884, 24Y885-24Y887, 24Y890	1
107b		STOP, cord, gland, 12 AWG, models 24M513, 24M523, 24M524, 24M526, 24Y880-24Y883	1
107c		PACKING, o-ring	1
107d		SEAL, spool, Size 10 models	1
107e		GROMMET, diaphragm, 12 AWG, 2.5 mm ² , models 24M513, 24M516, 24M523, 24M524, 24M526, 24M544, 24Y880 - 24Y883, 24Y888, 24Y889	
107f		GROMMET, diaphragm, 16 AWG, 1.5 mm ² , models 24M511, 24M529, 24M532, 24M535, 24M538, 24M541, 24Y879, 24Y884, 24Y885-24Y887, 24Y890	1
107g		CLAMP, wire, 12 AWG, 2.5 mm ² , models 24M513, 24M523, 24M524, 24M526, 24Y880-24Y883	1
107h		CLAMP, wire, 16 AWG, 1.5 mm ² , models 24M511, 24M529, 24M532, 24M535, 24M538, 24M541, 24Y879, 24Y884, 24Y885-24Y887, 24Y890	1
108	24N897	KIT, repair, roller bracket	
108a		BRACKET, roller	1
108b		ROLLER	4
108c		PIN, roller	4

Ref	Part No.	Description	Qty
108d		SCREW, M6 x 16	4
109	222225	KIT, repair, ball stop, 12 AWG and 2.5 mm ² cord	
	24N539	KIT, repair, ball stop, 16AWG cord	
	24N538	KIT, repair, ball stop, 1.5 mm ² cord	
109a		NUT, hex	2
109b		SCREW, mach. pnh	2
109c		BALL STOP	2
	24N871	KIT, socket, single, NEMA 5-20R	1
	24N872	KIT, socket, single, 16AWG	1
	16N226	KIT, tool tap, 125V, 12A	1
	16N223	KIT, light, fluorescent, 110V, without tool	1
	16N224	KIT, light, fluorescent, 110V with tool	1
	16N225	KIT, light, LED, 110V-240V	1
	127088	KIT, light, LED, Stubby II	1
	16P697	KIT, lamp, fluorescent, light, 110V	1
	16P696	KIT, lamp, LED, light, 110V-240V	1
	16P999	KIT, magnetic clip	1

Technical Data

Size 5 and Size 10 SD Series™ Cord and Light Reel		
	120V Models	230V Models
Voltage	120VAC	230VAC
Maximum Current	See Models, page 3	See Models, page 4
Wire Gauge	See Models, page 3	See Models, page 4
Cord Length		
Size 5	See Models, page 3 and 4	
Size 10	See Models, page 3 and 4	
Operating Temperature		
24M510-24M518, 24M521-24M526, 24M542-24M544, 24Y858-24Y864, 24Y873-24Y876, 24Y879-24Y883, 24Y888, 24Y889	-22°F to 122°F (-30°C to 50°C)	
24M527-24M541, 24Y865-24Y872, 24Y877, 24Y878, 24Y884- 24Y887, 24Y890	-4°F to 104°F (-20°C to 40°C)	
GFCI Models		
24M525, 24Y864	Complies with UL943 Section 6.7.2.1c requirements for open neutral protection for a portable GFCI.	
24M526, 24Y883		
Weight - without accessories		
120V Models		
Size 5: 16AWG, Cord Length - 35 Feet	25.4 lbs (11.5 kg)	
Size 5: 16AWG, Cord Length - 50 Feet	27.6 lbs (12.5 kg)	
Size 10: 16 AWG, Cord Length - 95 Feet	46.3 lbs (21.0 kg)	
Size 5: 12AWG, Cord Length - 35 Feet	28.2 lbs (12.8 kg)	
Size 5: 12AWG, Cord Length - 50 Feet	32.0 lbs (14.5 kg)	
Size 5: 12AWG, Cord Length - 75 Feet	51.1 lbs (23.2 kg)	
Size 10: 12 AWG, Cord Length - 95 Feet	51.8 lbs (23.5 kg)	
230V Models		
Size 5: 1,5 mm ² , Cord Length 10 m	25.6 lbs (11.6 kg)	
Size 5: 1,5 mm ² , Cord Length 15 m	30.6 lbs (13.9 kg)	
Size 10: 1,5 mm ² , Cord Length 25 m	49.4 lbs (22.4 kg)	
Size 10: 2,5 mm ² , Cord Length 25 m	54.1 lbs (24.5 kg)	
Dimensions		
Size 5 and Size 10	See page 34	
Sound Pressure*	80 dB(A)	
Sound Power**	87 dB(A)	

*All readings taken at assumed retraction rate, from assumed operator position.

**Sound Power tester per ISO 9614-2.

Dimensions - Size 5 and Size 10 Models

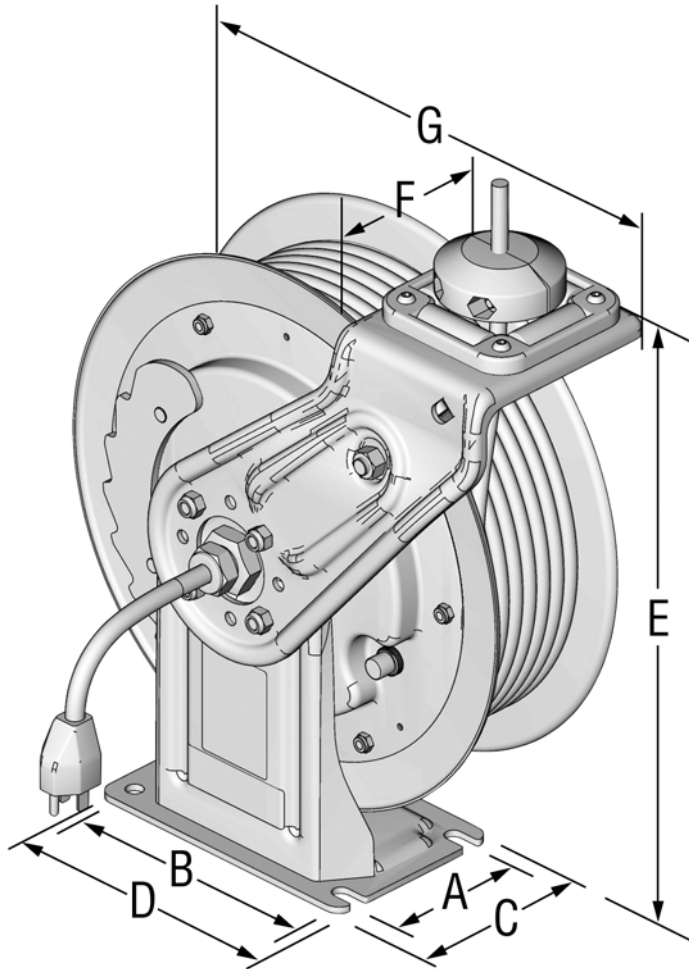

Size	A	B	C	D	E†	F◆	G★
Size 5	3.5 inches (89 mm)	6.38 inches (162 mm)	4.7 inches (120 mm)	7.48 inches (190 mm)	14.8 inches (376 mm)	6.6 inches (168 mm)	13.84 inches (352mm)
Size 10	3.5 inches (89 mm)	7.5 inches (191 mm)	4.7 inches (120 mm)	9 inches (229 mm)	19.5 inches (498 mm)	7 inches (177 mm)	17.5 inches (445 mm)

† Measurement taken from base to top of bolts.

◆ Measurement taken from end of the power cord strain relief to the spring cassette cover cap.

★ Measurement taken from edge of spool to front of the arm.

Graco SD Series™ Cord and Light Reel Warranty

Graco warrants all equipment referenced in this document which is manufactured by Graco and bearing its name to be free from defects in material and workmanship on the date of sale to the original purchaser for use. Graco will, for a period of two (2) years from the date of sale, repair or replace any non-electrical components of the equipment determined by Graco to be defective, and Graco will for a period of one (1) year from the date of sale, repair or replace any electrical components of the equipment determined by Graco to be defective. This warranty applies only when the equipment is installed, operated and maintained in accordance with Graco's written recommendations.

This warranty does not cover, and Graco shall not be liable for general wear and tear, or any malfunction, damage or wear caused by faulty installation, misapplication, abrasion, corrosion, inadequate or improper maintenance, negligence, accident, tampering, or substitution of non-Graco component parts. Nor shall Graco be liable for malfunction, damage or wear caused by the incompatibility of Graco equipment with structures, accessories, equipment or materials not supplied by Graco, or the improper design, manufacture, installation, operation or maintenance of structures, accessories, equipment or materials not supplied by Graco.

This warranty is conditioned upon the prepaid return of the equipment claimed to be defective to an authorized Graco distributor for verification of the claimed defect. If the claimed defect is verified, Graco will repair or replace free of charge any defective parts. The equipment will be returned to the original purchaser transportation prepaid. If inspection of the equipment does not disclose any defect in material or workmanship, repairs will be made at a reasonable charge, which charges may include the costs of parts, labor, and transportation.

THIS WARRANTY IS EXCLUSIVE, AND IS IN LIEU OF ANY OTHER WARRANTIES, EXPRESS OR IMPLIED, INCLUDING BUT NOT LIMITED TO WARRANTY OF MERCHANTABILITY OR WARRANTY OF FITNESS FOR A PARTICULAR PURPOSE.

Graco's sole obligation and buyer's sole remedy for any breach of warranty shall be as set forth above. The buyer agrees that no other remedy (including, but not limited to, incidental or consequential damages for lost profits, lost sales, injury to person or property, or any other incidental or consequential loss) shall be available. Any action for breach of warranty must be brought within two (2) years of the date of sale.

GRACO MAKES NO WARRANTY, AND DISCLAIMS ALL IMPLIED WARRANTIES OF MERCHANTABILITY AND FITNESS FOR A PARTICULAR PURPOSE, IN CONNECTION WITH ACCESSORIES, EQUIPMENT, MATERIALS OR COMPONENTS SOLD BUT NOT MANUFACTURED BY GRACO. These items sold, but not manufactured by Graco (such as electric motors, switches, hose, etc.), are subject to the warranty, if any, of their manufacturer. Graco will provide purchaser with reasonable assistance in making any claim for breach of these warranties.

In no event will Graco be liable for indirect, incidental, special or consequential damages resulting from Graco supplying equipment hereunder, or the furnishing, performance, or use of any products or other goods sold hereto, whether due to a breach of contract, breach of warranty, the negligence of Graco, or otherwise.

FOR GRACO CANADA CUSTOMERS

The Parties acknowledge that they have required that the present document, as well as all documents, notices and legal proceedings entered into, given or instituted pursuant hereto or relating directly or indirectly hereto, be drawn up in English. Les parties reconnaissent avoir convenu que la rédaction du présente document sera en Anglais, ainsi que tous documents, avis et procédures judiciaires exécutés, donnés ou intentés, à la suite de ou en rapport, directement ou indirectement, avec les procédures concernées.

Graco Information

For the latest information about Graco products, visit www.graco.com.

TO PLACE AN ORDER, contact your Graco distributor or call to identify the nearest distributor.

Phone: 612-623-6928 **or Toll Free:** 1-800-533-9655, **Fax:** 612-378-3590

All written and visual data contained in this document reflects the latest product information available at the time of publication. Graco reserves the right to make changes at any time without notice.

For patent information, see www.graco.com/patents.

Original instructions. This manual contains English. MM 3A2826

Graco Headquarters: Minneapolis

International Offices: Belgium, China, Japan, Korea

GRACO INC. AND SUBSIDIARIES • P.O. BOX 1441 • MINNEAPOLIS MN 55440-1441 • USA

Copyright 2012, Graco Inc. All Graco manufacturing locations are registered to ISO 9001.

www.graco.com

Revised March 2016